

**J.C. STEELE & SONS**

# **E Series Even Feeders**



*Double 88E Even Feeder with rear discharge*

## **E FEEDER**

Multiple material applications:

- Biosolids
- Bauxite
- Clays
- Coal fines
- Filter cakes
- Fly ash
- Gypsum
- Iron ore and oxide
- Laterite
- Lignite
- Manganese ore
- Mine paste
- Mullite
- Paper sludge
- Salts
- Sand
- Sawdust
- Scrap fiber cement board
- Scrap wallboard
- Sludges



The Global Leader in Stiff Extrusion

# Designed and engineered to deliver a more consistent, accurate feed for improved downstream processing

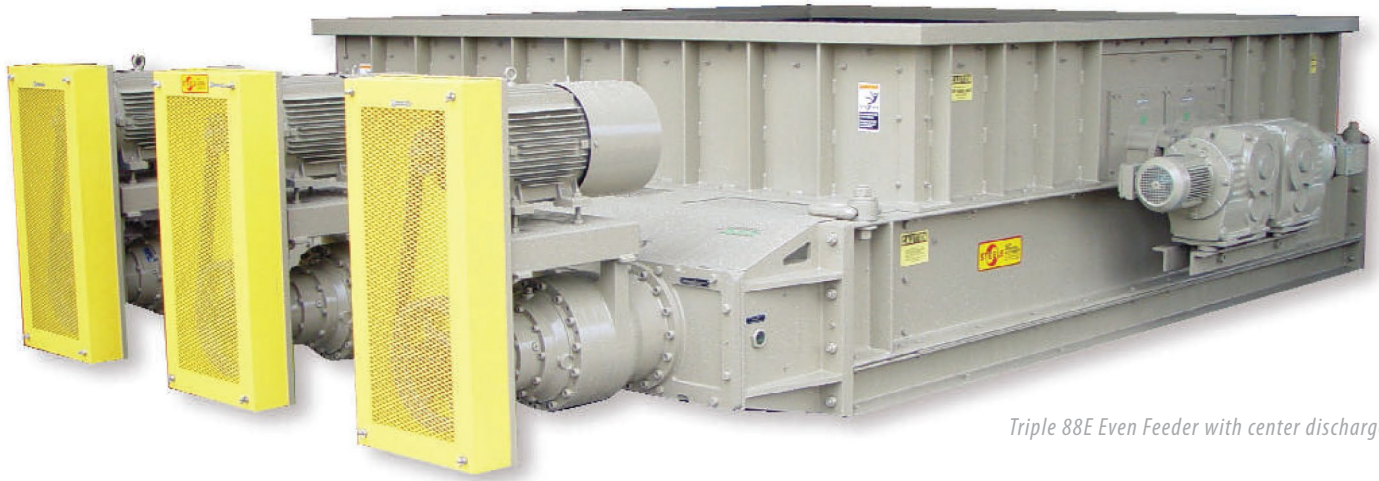

Triple 88E Even Feeder with center discharge

The Steele E Series Even Feeders are simple, durable machines for one application — delivering a consistent, accurate output for continuous processing downstream. They process a wide range of materials, from wet sticky clays, sludges and filter cakes to dry, granular and friable materials, without bridging or sticking.

Our even feeders provide dependable size reduction and consistent feeding of lumpy or friable materials, while requiring minimal maintenance and downtime for cleaning. If box feeders or belt feeders in your operation result in inconsistent production quality for downstream processing or excessive maintenance, you should consider the E Series. We can combine your choice of constant- or variable-speed drives, multiple shaft layouts, spiral configurations and special materials construction to match your specific application.

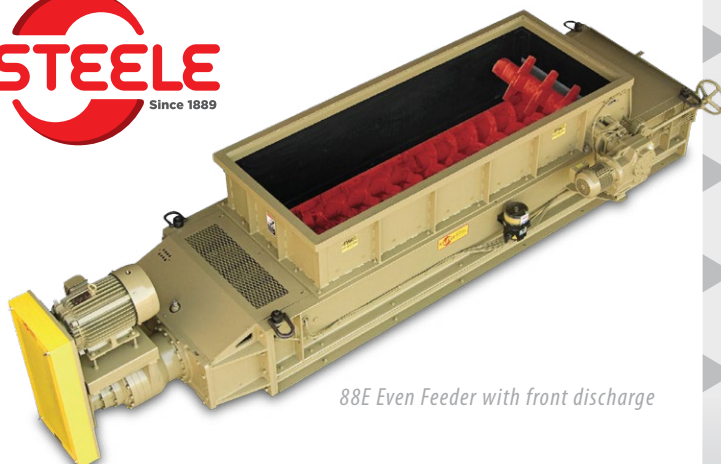

88E Even Feeder with front discharge

▶ **88E Even Feeder** — Four shafts, one drive train, for very dry to wet and sticky, without bridging over.

▶ **Double 88E Even Feeder** — Eight shafts and two independent, separate four-shaft drives, capable of feeding at approximately twice the 88E rate. Large hopper area increases storage and discharge capacity, while preventing bridge-over with sticky materials. Multiple drives offer redundancy.

▶ **Triple 88E Even Feeder** — Twelve shafts with three independent, separate four-shaft drives. Larger hopper area for increased storage and discharge capacity. More redundancy than the double.

▶ **124E Even Feeder** — Four spiral shafts with one drivetrain. 50% longer hopper than the 88E, designed to accommodate bucket loading with front-end loader.

▶ **Double 124E Even Feeder** — Eight shafts, two independent, separate four-shaft drives, plus extra-large hopper for high throughput and no bridge-over.

▶ **Triple 124E Even Feeder** — The largest hopper of our standard feeders.

▶ **Center Discharge Even Feeders** — The largest hoppers, highest throughput and best bin flow of all of our feeders.

▶ **Feeder Beds** — Feeder beds available for suspension from bin flanges of the hopper.

## The durability and reliability you need

We use high-grade structural steel in our primary frame construction and cast wearing parts with our 28PC alloy. AGMA-class hobbed gears between spiral shafts are rated for 80,000-plus hours at full load. Built-in overload protection reduces potential damage to spirals, spiral shafts, gears and bearings from tramp iron, hard rocks and other unfeedable materials.

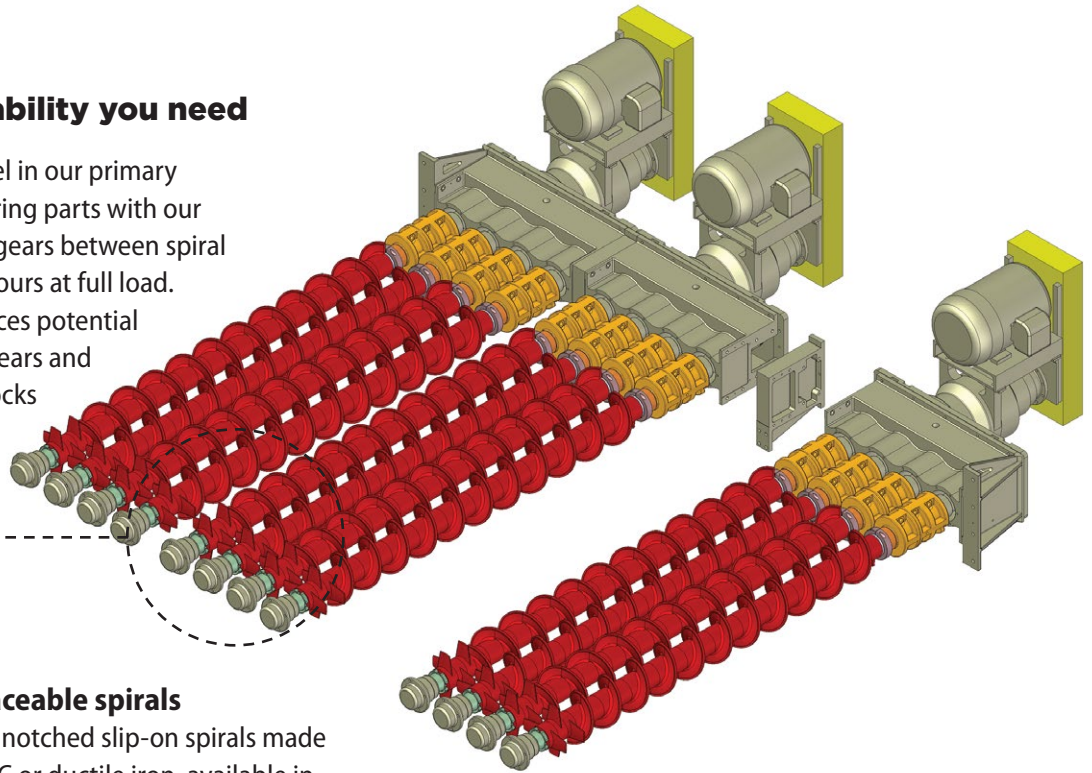

### Replaceable spirals

Full or notched slip-on spirals made of 28PC or ductile iron, available in multiple configurations. Fabricated spirals available for special applications.

### The flexibility to fit your application

- Single feeders — one drive/four shafts
- Double feeders — two drives/eight shafts
- Triple feeders — three drives/twelve shafts

### Optional cross shafts

Improved feed consistency and bin flow, with chopping and shredding to reduce soft and friable materials.

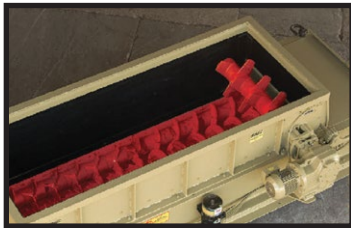

### Automatic greasing systems

Better greasing accuracy and consistency, with lower maintenance costs and grease consumption.



### Optional sliding floor

Eliminates cross-contamination while providing faster clean-outs for frequent material changes.



### Other options for your specific materials and applications

You can connect these machines to additional downstream processes, improve access to wearing and replacement parts, and add more control. We also offer a handwheel-operated gate, expanded discharge zone for sticky materials, hanging installations, direct coupled motors and special materials (UHMW liners and other wetted parts in stainless steel, stainless coated or other materials).

For more information on the E Series Even Feeders and the value they add to your manufacturing process, talk to your regional J.C. Steele sales representative, call us at **1.704.872.3681** (in the U.S., call toll-free at **800.278.3353**) or visit [www.jcsteele.com](http://www.jcsteele.com).



The Global Leader in Stiff Extrusion

# General Specifications - STEELE E Series Even Feeders

Input size	Uncrushables, stones, etc. up to 2.5 inches (65 mm) Friable, lumpy materials up to 40 inches (1000 mm)	
Shredded output size	<100 mm (4 inches)	
Standard hopper opening	Width	Length
	Min: 1040 mm	Min: 1810 mm
	Max: 3225 mm	Max: 4190 mm
Loading options	Front-end loader, fork lift, conveyor	
Material characteristics	Wet, sticky abrasives to dry, sandy and powdery	
Replaceable cast spirals	250 mm (10 inches) high-chrome white iron or ductile iron	
Spiral shafts	100 mm (3.9 inches) diameter cold-rolled steel	
Coating/liner options	Epoxy paint, UHMW, stainless steel, etc.	
Bearings	Self-aligning, sealed roller	
	L <sub>10</sub> Life >50,000 hours at full load	
Gearing	AGMA-class hobbed, through-hardened	
	50,000 hours at full load	
Motors	AC, hydraulic, constant- and variable-speed	
Reducers	High-torque planetary reducers available in three reduction ratios for different RPM ranges	
Spiral shaft speeds (normal)	0-40 RPM	
Modular drive multiples	Single 4 shafts / Double 8 shafts / Triple 12 shafts	
Discharge options	Front, center or rear	
Maximum output (40 RPM)	Single: 85 m <sup>3</sup> /hr	Center discharge: 170 m <sup>3</sup> /hr
	Double: 170 m <sup>3</sup> /hr	Center discharge: 340 m <sup>3</sup> /hr
	Triple: 255 m <sup>3</sup> /hr	Center discharge: 510 m <sup>3</sup> /hr

## Multiple discharge locations

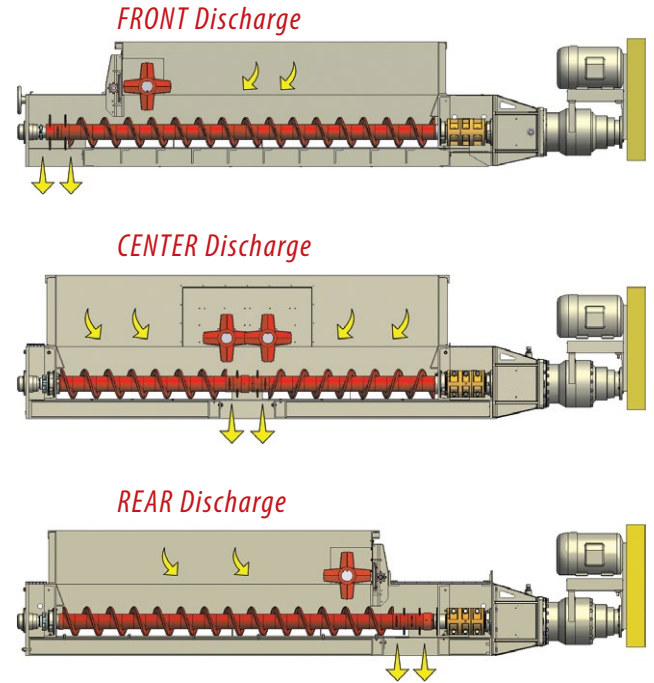

Contact J.C. Steele for specific dimensions.

## Feeder width dimensions — Most common models only

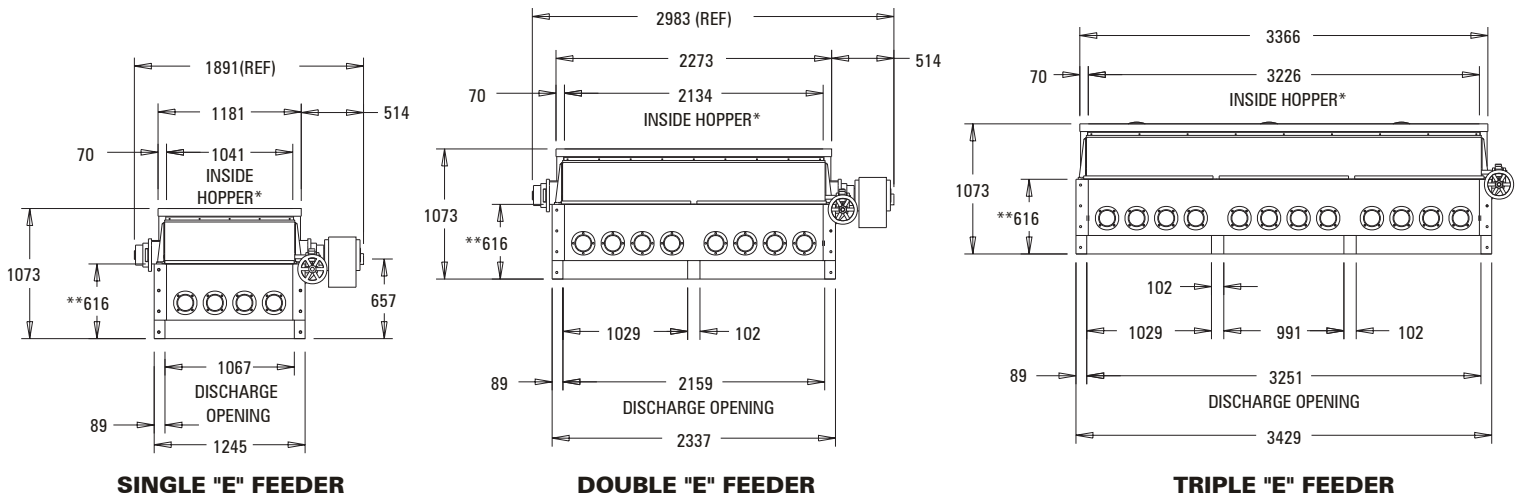

NOTE: Dimensions in mm. \* Internal hopper dimensions do not include liners. \*\* Base hopper height. Contact J.C. Steele for specific machine and hopper dimensions.

J.C. Steele even feeders are available with application engineering, line layout and design, start-up assistance, service and parts all over the world. For more information on the E Series Even Feeders and the value they add to your manufacturing process, talk to your regional J.C. Steele sales representative, call us at **1.704.872.3681** (in the U.S., call toll-free at **800.278.3353**) or visit **www.jcsteele.com**.

